

01 - 08.1

10.05.GB

**LDM valves
with SPA Praha actuators**



Kv coefficient calculation

Calculation itself is carried out with respect to conditions of regulating circuit and operating medium according to equations mentioned below. Control valve must be designed to be able to regulate maximal flow quantity at given operating conditions. At the same time it is necessary to check whether minimal flow quantity can be even regulated or not.

Condition is the following ratio $r > Kvs / Kv_{min}$

Because of eventual minus tolerance 10% of Kv_{100} against Kvs and requirement for possible regulation within range of maximal flow (decrement and increase of flow), producer recommends to select Kvs value higher than maximal operating Kv value:

$$Kvs = 1.1 \div 1.3 Kv$$

It is necessary to take into account to which extent Q_{max} involve "precautionary additions" that could result in valve oversizing.

Relations of Kv calculation

		Pressure drop $p_2 > p_1/2$ $\Delta p < p_1/2$	Pressure drop $\Delta p \geq p_1/2$ $p_2 \leq p_1/2$
Kv =	Liquid	$\frac{Q}{100} \sqrt{\frac{\rho_1}{\Delta p}}$	$\frac{2 \cdot Q_n \cdot \sqrt{\rho_n \cdot T_1}}{5141 \cdot p_1}$
	Gas	$\frac{Q_n \cdot \sqrt{\rho_n \cdot T_1}}{5141 \cdot \Delta p \cdot p_2}$	$\frac{2 \cdot Q_n \cdot \sqrt{\rho_n \cdot T_1}}{5141 \cdot p_1}$
	Superh. steam	$\frac{Q_m}{100} \sqrt{\frac{v_2}{\Delta p}}$	$\frac{Q_m}{100} \sqrt{\frac{2v}{p_1}}$
	Sat. steam	$\frac{Q_m}{100} \sqrt{\frac{v_2 \cdot x}{\Delta p}}$	$\frac{Q_m}{100} \sqrt{\frac{2v \cdot x}{p_1}}$

Above critical flow of vapours and gases

When pressure ratio is above critical ($p_2 / p_1 < 0.54$), speed of flow reaches acoustic velocity at the narrowest section. This event can cause higher level of noisiness. Then it is convenient to use a throttling system ensuring low noisiness (multi-step pressure reduction, damping orifice plate at outlet).

Dimensions and units

Marking	Unit	Name of dimension
Kv	$m^3 \cdot h^{-1}$	Flow coefficient under condition of units of flow
Kv_{100}	$m^3 \cdot h^{-1}$	Flow coefficient at nominal stroke
Kv_{min}	$m^3 \cdot h^{-1}$	Flow coefficient at minimal flow rate
Kvs	$m^3 \cdot h^{-1}$	Valve nominal flow coefficient
Q	$m^3 \cdot h^{-1}$	Flow rate in operating conditions (T_1, p_1)
Q_n	$Nm^3 \cdot h^{-1}$	Flow rate in normal conditions ($0^\circ C, 0.101 Mpa$)
Q_m	$kg \cdot h^{-1}$	Flow rate in operating conditions (T_1, p_1)
p_1	MPa	Upstream absolute pressure
p_2	MPa	Downstream absolute pressure
p_s	MPa	Absolute pressure of saturated steam at given temperature (T_1)
Δp	MPa	Valve differential pressure ($\Delta p = p_1 - p_2$)
ρ_1	$kg \cdot m^{-3}$	Process medium density in operating conditions (T_1, p_1)
ρ_n	$kg \cdot Nm^{-3}$	Gas density in normal conditions ($0^\circ C, 0.101 Mpa$)
v_2	$m^3 \cdot kg^{-1}$	Specific volume of steam when temperature T_1 and pressure p_2
v	$m^3 \cdot kg^{-1}$	Specific volume of steam when temperature T_1 and pressure $p_1/2$
T_1	K	Absolute temperature at valve inlet ($T_1 = 273 + t_1$)
x	1	Proportionate weight volume of saturated steam in wet steam
r	1	Rangeability

Flow characteristic selection in regard of valve stroke

To make right selection of valve flow characteristic, it is suitable to carry out checking of what stroke values will be reached in different operation states. We recommend to carry out such checking at least for minimal, nominal and maximal flow rates. The principle for flow characteristic selection is to avoid, if possible, 5-10% of the beginning and end of the valve stroke range.

To calculate valve stroke at different operating conditions with different types of flow characteristics is possible with the advantage of using LDM's calculation programme VALVES. The programme serves for complete design of valve from Kv calculation to specification of a concrete valve with its actuator.

Valve flow characteristics

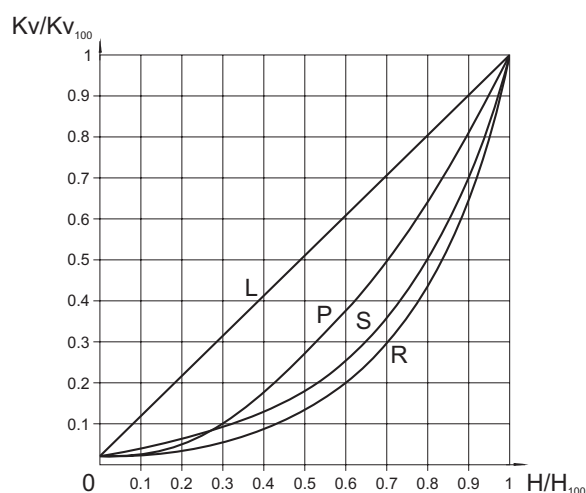

- L - linear characteristic
 $Kv/Kv_{100} = 0.0183 + 0.9817 \cdot (H/H_{100})$
- R - equal-percentage characteristic (4-percentage)
 $Kv/Kv_{100} = 0.0183 \cdot e^{(4 \cdot H/H_{100})}$
- P - parabolic characteristic
 $Kv/Kv_{100} = 0.0183 + 0.9817 \cdot (H/H_{100})^2$
- S - LDM spline characteristic
 $Kv/Kv_{100} = 0.0183 + 0.269 \cdot (H/H_{100}) - 0.380 \cdot (H/H_{100})^2 + 1.096 \cdot (H/H_{100})^3 - 0.194 \cdot (H/H_{100})^4 - 0.265 \cdot (H/H_{100})^5 + 0.443 \cdot (H/H_{100})^6$

Principles for plug type selection

V-ported plugs should not be used in above - critical differential pressures with inlet pressure $p_1 \geq 0,4$ MPa and for regulation of saturated steam. In these cases we recommend to use a perforated plug. The perforated plug should be also used always when cavitation may occur due to a high differential pressure value or valve ports erosion caused by high speed of process medium flow. If the parabolic plug is used (because of small Kvs) for pressures $p_1 \geq 1,6$ MPa and above - critical differential pressures, it is necessary to close both plug and seat with a hard metal overlay, i.e. stellite trim.

Packing - O -ring EPDM

Packing is designed for non-aggressive media with temperature from 0°C to 140°C. Packing excels with its reliability and long time tightness. It has ability of sealing even if the valve stem is a bit damaged. Low frictional forces enables valve to be actuated with a low-linear-force actuator. Service life of sealing rings depends on operating conditions and it is more than 400 000 cycles on average.

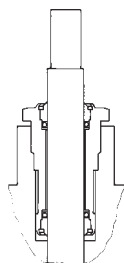

Applied to RV 2xx

Packing - DRSpack® (PTFE)

DRSpack® (Direct Radial Sealing Pack) is a packing with high tightness at both low and high operating pressure values. It is the most used type of packing suitable for temperatures ranging from 0°C to 260°C. The pH range is from 0 to 14. The packing enables using of actuators with low linear force. The design enables an easy change of the whole packing. The average service life of DRSpack® is more than 500 000 cycles.

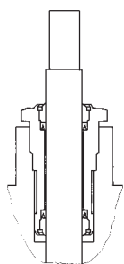

Service life of bellows packing

Bellows material	Temperature				
	200°C	300°C	400°C	500°C	550°C
1.4541	100 000	40 000	28 000	7 000	not applicable
1.4571	90 000	34 000	22 000	13 000	8 000

Values specified in the table above show minimal guaranteed number of cycles with the valve full stroke when the bellows is fully lengthened and pressed. In regulation, when the valve

Packing - Graphite

This type of packing can be used for media with temperature up to 550°C and pH range: 0 to 14. Packing can be "sealed up" either by screwing the packing screw in or adding another sealing ring. In regard of intensive frictional forces, graphite packing is suitable for actuators with a sufficient linear force.

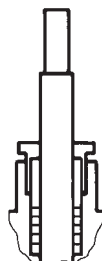

Packing - Bellows

Bellows packing is suitable for low and high temperatures ranging from -50°C to 550°C. Bellows ensures absolute tightness to environment. Packing is equipped with safety PTFE packing as standard to prevent medium from leaking in case of damage to bellows. Intensive linear forces are not required.

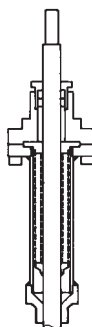

Application of bellows packing

Bellows packing is suitable for applications with very aggressive, toxic or other dangerous media that require absolute tightness to environment. In such case, it is necessary to check compatibility of used body material as well as the valve inner parts material with process medium. It is recommended to use bellows with safety packing preventing medium from leaking in case of damage to bellows when there is an extremely dangerous process medium used.

Bellows is also a great solution to use of process medium either with temperature below zero when ice accretions cause premature damage to packing or with high temperatures when bellows ensures medium cooling.

moves only in a portion of the stroke range at the inner centre of the valve, the service life of the bellows is many times longer then depending on concrete operating conditions.

Procedure for designing of two-way valve

Given: medium water, 155°C, static pressure at piping spot 1000 kPa (10 bar), $\Delta p_{DISP} = 80$ kPa (0,8 bar), $\Delta p_{PIPELINE} = 15$ kPa (0,15 bar), $\Delta p_{APPLIANCE} = 25$ kPa (0,25 bar), nominal flow rate $Q_{NOM} = 8$ m³·h⁻¹, minimal flow rate $Q_{MIN} = 1,3$ m³·h⁻¹.

$$\Delta p_{DISP} = \Delta p_{VALVE} + \Delta p_{APPLIANCE} + \Delta p_{PIPELINE}$$

$$\Delta p_{VALVE} = \Delta p_{DISP} - \Delta p_{APPLIANCE} - \Delta p_{PIPELINE} = 80 - 25 - 15 = 40 \text{ kPa (0,4 bar)}$$

$$Kv = \frac{Q_{NOM}}{\sqrt{\Delta p_{VALVE}}} = \frac{8}{\sqrt{0,4}} = 12,7 \text{ m}^3 \cdot \text{h}^{-1}$$

Precautionary additions for process tolerances (provided that flow rate Q was not oversized):

$$Kvs = (1,1 \text{ to } 1,3) \cdot Kv = (1,1 \text{ to } 1,3) \cdot 12,7 = 14 \text{ to } 16,5 \text{ m}^3 \cdot \text{h}^{-1}$$

Now we choose the nearest Kvs value from those available in our catalogue, i.e. $Kvs = 16$ m³·h⁻¹. This value corresponds to nominal size of DN 32. Then if we choose flanged execution PN 16, body made of spheroidal cast iron, with metal - PTFE seat sealing, packing PTFE and equal-percentage flow characteristic, we will get the following specification No.:

RV 21x XXX 1423 R1 16/220-32

x in the valve code above (21x) stands for valve execution (direct or reverse) and depends on type of used actuator which should be chosen in respect to demands of regulating system (type, producer, voltage, type of control, necessary torque or linear force, etc.)

Determination of real pressure drop Value of a chosen valve at fully open

$$\Delta p_{VALVE H100} = \left(\frac{Q_{NOM}}{Kvs} \right)^2 = \left(\frac{8}{16} \right)^2 = 0,25 \text{ bar (25 kPa)}$$

The control valve's real pressure drop calculated this way shall be taken into account in a hydraulic calculation of regulating

Determination of valve's real authority

$$a = \frac{\Delta p_{VALVE H100}}{\Delta p_{VALVE H0}} = \frac{25}{80} = 0,31$$

Value *a* should be at least equal to 0,3. A chosen valve checking is then satisfactory.

Caution: the valve's authority calculation should be related to a valve pressure difference in its closed position i.e. disposition pressure value in a branch Δp_{AVAIL} when flow rate is zero, not to a pressure value of a pump Δp_{PUMP} , because, due to pipeline circuit pressure drops up to the spot where the regulating branch is connected, the following equation applies: $\Delta p_{AVAIL} < \Delta p_{PUMP}$. In such cases we consider for simplicity the following: $\Delta p_{AVAIL H100} = \Delta p_{AVAIL H0} = \Delta p_{DISP}$.

Checking of rangeability

We carry out the same checking for minimal flow rate $Q_{MIN} = 1,3$ m³·h⁻¹. The following differential pressure values correspond to the min. flow rate: $\Delta p_{APPLIANCE QMIN} = 0,40$ kPa, $\Delta p_{PIPELINE QMIN} = 0,66$ kPa. $\Delta p_{VALVE QMIN} = 80 - 0,4 - 0,66 = 78,94 = 79$ kPa.

$$Kv_{MIN} = \frac{Q_{MIN}}{\sqrt{\Delta p_{VALVE QMIN}}} = \frac{1,3}{\sqrt{0,79}} = 1,46 \text{ m}^3 \cdot \text{h}^{-1}$$

Necessary rangeability value

$$r = \frac{Kvs}{Kv_{MIN}} = \frac{16}{1,46} = 11$$

shall be lower than mentioned rangeability value of $r = 50$. Checking is then satisfactory.

Selection of suitable flow characteristic

On the basis of calculated values Kv_{NOM} and Kv_{MIN} , it is possible to read the appropriate stroke values from the graph for individual types of flow characteristics of the valve and choose the most suitable one accordingly. Here we have $h_{NOM} = 96\%$, $h_{MIN} = 41\%$ for equal-percentage characteristic. In that case, LDMspline® flow characteristic is more suitable (93% and 30% of the stroke). It corresponds to the following specification code :

RV 21x XXX 1423 S1 16/220-32

Scheme of typical regulation loop with the application of two-way control valve

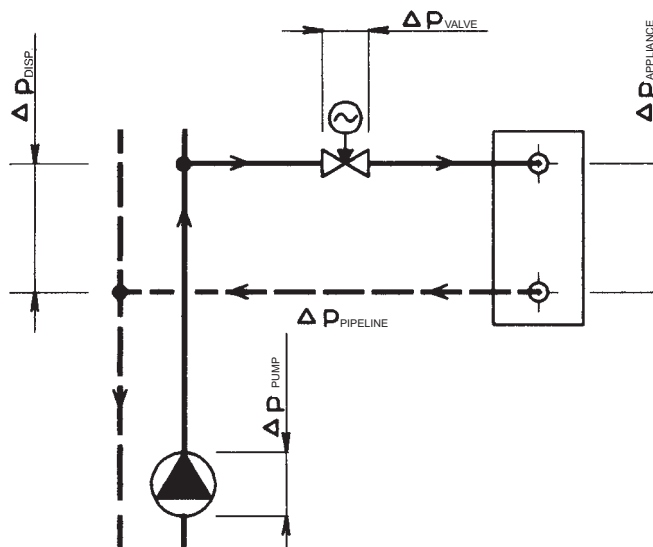

Remark: More detailed information on calculation and design of LDM control valves is mentioned in calculation instructions No. 01-12.0. Equations mentioned above apply in a simplified way to water. To reach optimum results, we recommend to use original calculation programme VALVES which is available on request free of charge.

Procedure for designing of three-way valve

Given: medium water, 90°C, static pressure at piping spot 1000 kPa (10 bar), $\Delta p_{\text{PUMP2}} = 40 \text{ kPa}$ (0,4 bar), $\Delta p_{\text{PIPELINE}} = 10 \text{ kPa}$ (0,1bar), $\Delta p_{\text{APPLIANCE}} = 20 \text{ kPa}$ (0,2 bar), flow rate $Q_{\text{NOM}} = 7 \text{ m}^3 \cdot \text{h}^{-1}$

$$\Delta p_{\text{PUMP2}} = \Delta p_{\text{VALVE}} + \Delta p_{\text{APPLIANCE}} + \Delta p_{\text{PIPELINE}}$$

$$\Delta p_{\text{VALVE}} = \Delta p_{\text{PUMP2}} - \Delta p_{\text{APPLIANCE}} - \Delta p_{\text{PIPELINE}} = 40 - 20 - 10 = 10 \text{ kPa} (0,1\text{bar})$$

$$Kv = \frac{Q_{\text{NOM}}}{\sqrt{\Delta p_{\text{VALVE}}}} = \frac{7}{\sqrt{0,1}} = 22,1 \text{ m}^3 \cdot \text{h}^{-1}$$

Precautionary additions for process tolerances (provided that flow rate Q was not oversized):

$$Kvs = (1,1 \text{ to } 1,3) \cdot Kv = (1,1 \text{ to } 1,3) \cdot 22,1 = 24,3 \text{ to } 28,7 \text{ m}^3 \cdot \text{h}^{-1}$$

Now we choose the nearest Kvs value from those available in our catalogue, i.e. $Kvs = 25 \text{ m}^3 \cdot \text{h}^{-1}$. This value corresponds to nominal size of DN 40. Then if we choose flanged execution PN 16, body made of spheroidal cast iron, with metal - PTFE seat sealing, packing PTFE and equal-percentage flow characteristic, we will get the following specification No.:

RV 21x XXX 1413 L1 16/140-40

x in the valve code above (21x) stands for valve execution (direct or reverse) and depends on type of used actuator which should be chosen in respect to demands of regulating system (type, producer, voltage, type of control, necessary torque or linear force, etc.)

Determination of real pressure drop value of a chosen valve at fully open

$$\Delta p_{\text{VALVE H100}} = \left(\frac{Q_{\text{NOM}}}{Kvs} \right)^2 = \left(\frac{7}{25} \right)^2 = 0,08 \text{ bar} (8 \text{ kPa})$$

The control valve's real pressure drop calculated this way shall be taken into account in a hydraulic calculation of regulating circuit.

Caution: To ensure reliable function of three-way valves, the most important condition is to keep minimum available pressure difference between A and B ports. Three-way valves are capable to manage even high pressure difference between A and B ports but valve's flow characteristic deformats then and so regulation properties deteriorate. So if in doubt about pressure difference value between those two ports (e.g. when three-way valve is piped directly into primary side without pressure separation), we recommend to use a two-way valve in combination with a primary-secondary side short cut to ensure a reliable regulation. The authority of A-AB way of three-way valve is, providing a constant flow rate in appliance circuit, the following:

$$a = \frac{\Delta p_{\text{VALVE H100}}}{\Delta p_{\text{VALVE H0}}} = \frac{8}{8} = 1 ,$$

which means that the behaviour of flow in A-AB way corresponds to ideal flow curve of the valve. In that case there are Kvs values in both ports the same with linear characteristic i.e. the total flow is nearly constant.

A combination of equal-percentage characteristic in A port and linear characteristic in B port shall be selected in those cases when loading of A port with differential pressure against B port cannot be avoided or when the primary side parametres are too high.

Scheme of a typical regulation loop with the application of a three-way mixing control valve

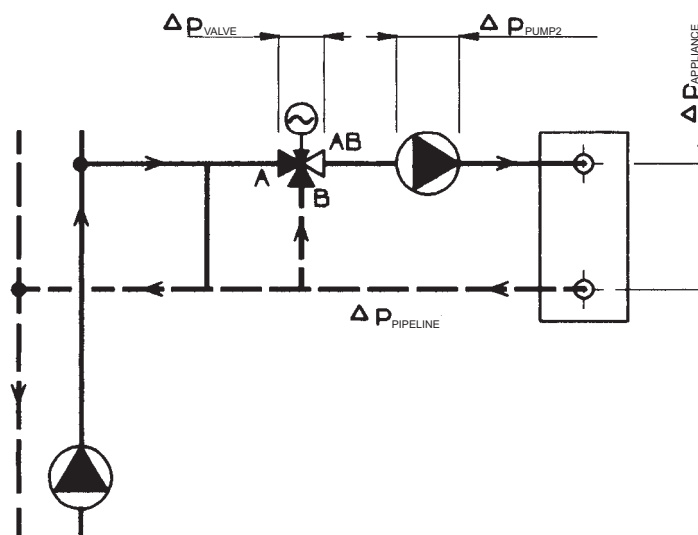

Remark: More detailed information on calculation and design of LDM control valves is mentioned in calculation instructions No. 01-12.0. Equations mentioned above apply in a simplified way to water. To reach optimum results, we recommend to use original calculation programme VALVES which is available on request free of charge.

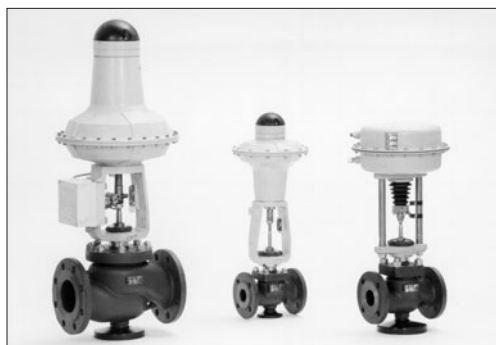

RV / UV 2x0 P (Ex)

**Control and Shut-off valves
DN 15 - 150, PN 16 and 40
with SPA Praha pneumatic actuators**

Description

Control valves RV / UV 210 (Ex), RV / UV 220 (Ex) and RV / UV 230 [further only RV/UV 2x0 (Ex)] are single-seated valves designed for regulation and shut-off of process medium flow. In regard of used actuators, the valves are suitable for regulation at low and medium high differential pressures. Flow characteristics, Kvs values and leakage rates correspond to international standards.

Valves RV/UV 2x0 (Ex) are especially designed for pneumatic actuators of SPA Praha.

Application

The valves series RV / UV 2x0 are designed for applications in heating, ventilation, power generation and chemical processing industries. The valves RV / UV 2x0 Ex meet the requirements II 1/2G IIB acc. to ČSN-EN 13 463-1 (9/2002) and ČSN EN 1127-1 (9/1998), and in connection with suitable actuators, they are also designed for applications in gas and chemical industries. Valve body can be optionally made of spheroidal cast iron, cast steel and stainless steel.

The materials selected correspond to recommendations stipulated by ČSN-EN 1503-1 (1/2002) (steels) and ČSN-EN 1503-3 (1/2002) (cast). The maximal permissible operating pressures in behaviour with types of material and temperature are specified in the table on page 25 of this catalogue.

Process media

Valves series RV (UV) 2x0 are designed for regulation (RV 2x0) and shut-off (UV 2x0) of flow and pressure of liquids, gases and vapours without abrasive particles e.g. water, steam, air and other media compatible with material of the valve inner parts. The valves series RV / UV 2x0 Ex are also designed for control and shut-off of the flow and pressure of technical and fuel gases and inflammable liquids. The usage of the valve made of spheroidal cast iron (RV 210) for steam is limited by the following parameters. The steam must be superheated (its dryness at valve outlet $x_v \geq 0,98$) and inlet pressure $p_1 \leq 0,4$ MPa when differential pressure is of above-critical value, and $p_1 \leq 1,6$ MPa when differential pressure is of under-critical value. In case these two conditions are not kept, it is necessary to use the valve made of cast steel (RV 220). To ensure a reliable regulation, the producers recommends to pipe a strainer in front of the valve into pipeline or ensure in any other way that process medium does not contain abrasive particles or impurities.

Installation

The valve is to be piped the way so that the direction of medium flow will coincide with the arrows on the body.

The valve can be installed in any position except position when the actuator is under the valve body. When medium temperature exceeds 150°C, it is necessary to protect the actuator against glowing heat from the pipeline e.g. by the means of proper insulating of the pipeline and valve or by tilting the valve away from the heat radiation.

Technical data

Series	RV / UV 210 (Ex)	RV / UV 220 (Ex)	RV / UV 230 (Ex)
Type of valve	Two-way, single-seated, control (shut-off) valve		
Nominal size range	DN 15 to 150		
Nominal pressure	PN 16, PN 40		
Body material	Spheroidal cast iron EN-JS 1025 (EN-GJS-400-10-LT)	Cast steel 1.0619 (GP240GH) 1.7357 (G17CrMo5-5)	Stainless steel 1.4581 (GX5CrNiMoNb19-11-2)
Seat material : DN 15 - 50	1.4028 / 17 023.6	1.4028 / 17 023.6	1.4571 / 17 347.4
DIN W.Nr./+ČSN DN 65 - 150	1.4027 / 42 2906.5	1.4027 / 42 2906.5	1.4581 / 42 2941.4
Plug material : DN 15 - 65	1.4021 / 17 027.6	1.4021 / 17 027.6	1.4571 / 17 347.4
DIN W.Nr./+ČSN DN 80 - 150	1.4027 / 42 2906.5	1.4027 / 42 2906.5	1.4581 / 42 2941.4
Operating temperature range	-20 to 300°C	-20 to 500°C	-20 to 400°C
Face to face dimensions	Section 1 acc. to ČSN-EN 558-1 (3/1997)		
Connection flanges	Acc. to ČSN-EN 1092-1 (4/2002)		
Flange faces	Type B1 (raised-faced) or Type F (female) acc. to ČSN-EN 1092-1 (4/2002)		
Type of plug	V-ported, contoured, perforated		
Flow characteristic	Linear, equal-percentage, LDMspline®, parabolic, on - off		
Kvs value	0.1 to 360 m ³ /hour		
Leakage rate	Class III. acc. to ČSN-EN 1349 (5/2001) (<0.1% Kvs) for c. valves with metal-metal seat sealing Class IV. acc. to ČSN-EN 1349 (5/2001) (<0.01% Kvs) for c. valves with metal-PTFE seat sealing		
Leakage rate for Ex version	Leakage rate 6 acc. to ČSN 13 3060 - section 2		
Regentability r	50 : 1		
Packing	O - ring EPDM $t_{max}=140^{\circ}C$, DRSpack® (PTFE) $t_{max}=260^{\circ}C$, Exp. graphite, bellows $t_{max}=500^{\circ}C$		

Remark: For low operating temperatures (-200 to +250°C), it is possible to supply the valve RV / UV 230 with body material made of 1.4308 (cast stainless steel).

Kvs values and differential pressures

Δp_{max} value is the valve max. differential pressure when open-close function is always guaranteed. In regard of service life of seat and plug, it is recommended so that permanent

differential pressure would not exceed 1.6 MPa. Otherwise it is suitable to use perforated plug or sealing surfaces of seat and plug with a hard metal overlay.

For further information on actuating, see actuators' catalogue sheets

¹⁾ Execution TANDEM

		Pneumatic actuator									526 61		5222							
		Fail-safe action									direct	indirect	direct	indirect	indirect ¹⁾					
		Spring range									20-100 kPa	40-200 kPa	20-100 kPa	160-300 kPa	160-300 kPa					
		Spring setting									20-100 kPa	75-235 kPa	20-100 kPa	160-300 kPa	160-300 kPa					
		Feeding pressure									250 kPa	250 kPa	320 kPa	320 kPa	320 kPa					
		Specification No. of actuator									52661.x11x	52661.x22x	5222x011...	5222x092...	5222x192...					
		Marking in valve specification No.									PJA, PJB		PJE, PJF							
		Linear force									3,5 kN	1,88 kN	8,4 kN	6,3 kN	12,5 kN					
DN	H	Kvs [m ³ /hod.]									Δp_{max}		Δp_{max}		Δp_{max}					
		1	2	3	4	5	6	7	8	9	metal	PTFE	metal	PTFE	metal	PTFE	metal	PTFE		
15	16	---	2.5 ¹⁾	1.6 ¹⁾	1.0 ¹⁾	0.6 ¹⁾	0.4 ¹⁾	0.25 ¹⁾	0.16 ³⁾	0.1 ³⁾	4.00	---	4.00	---	4.00	---	4.00	---	---	---
15		4.0 ¹⁾	---	---	---	---	---	---	---	---	4.00	---	4.00	---	4.00	---	4.00	---	---	---
20		---	---	2.5 ¹⁾	1.6 ¹⁾	1.0 ¹⁾	0.6 ¹⁾	---	---	---	4.00	---	4.00	---	4.00	---	4.00	---	---	---
20		---	4.0 ¹⁾	---	---	---	---	---	---	---	4.00	---	4.00	---	4.00	---	4.00	---	---	---
20		6.3 ¹⁾	---	---	---	---	---	---	---	---	4.00	---	2.70	---	4.00	---	4.00	---	---	---
25		---	---	---	2.5 ¹⁾	1.6 ¹⁾	---	---	---	---	4.00	---	4.00	---	4.00	---	4.00	---	---	---
25		10.0	6.3 ²⁾	4.0 ²⁾	---	---	---	---	---	---	4.00	4.00	1.60	2.00	4.00	4.00	4.00	4.00	---	---
32		---	---	---	4.0 ¹⁾	---	---	---	---	---	4.00	---	4.00	---	4.00	---	4.00	---	---	---
32		16.0	10.0	6.3 ²⁾	---	---	---	---	---	---	2.70	3.00	0.90	1.20	4.00	4.00	4.00	4.00	---	---
40		25.0	16.0	10.0	---	---	---	---	---	---	1.70	1.90	0.50	0.77	4.00	4.00	3.82	4.00	---	---
50	25	40.0	25.0	16.0	---	---	---	---	---	0.96	1.15	0.26	0.46	3.14	3.33	2.25	2.44	---	---	
65		63.0	40.0	25.0	---	---	---	---	---	0.55	0.70	0.12	0.27	1.88	2.03	1.33	1.49	---	---	
80		100.0	63.0	40.0	---	---	---	---	---	---	---	---	---	1.17	1.30	0.79	0.92	1.91	2.03	
100	40	160.0	100.0	63.0	---	---	---	---	---	---	---	---	---	0.73	0.84	0.49	0.59	1.21	1.32	
125		250.0	160.0	100.0	---	---	---	---	---	---	---	---	---	0.46	0.54	0.30	0.38	0.77	0.85	
150		360.0	250.0	160.0	---	---	---	---	---	---	---	---	---	---	0.31	0.38	0.20	0.27	0.52	0.60

- 1) parabolic plug
 - 2) V-ported plug with linear characteristic, parabolic plug with equal-percentage, LDMspline[®] and parabolic characteristic.
 - 3) valve with micro-throttling trim. Execution with Kvs 0.01 to 0.063 m³/hour is possible after agreement with the producer.
- Equal-percentage, LDMspline[®] and parabolic characteristic available on condition : Kvs value ≥ 1.0
- Perforated plug available only with Kvs values in shadowed frames with the following restrictions:
- Kvs values 2.5 to 1.6 m³/hour available with linear characteristic only.
 - Perforated plug with Kvs value acc. to column No. 2 available with linear or parabolic characteristic only.

Max. differential pressure Δp for valves PN 16 must be 1.6 MPa.
 metal - version with metal - metal seat sealing
 PTFE - version with metal - PTFE seat sealing (is not applicable to contoured plugs)

Max. differential pressures specified in table apply to PTFE and O-ring packing. Δp_{max} for bellows must be consulted with the producer. It applies to graphite packing as well especially when required Δp value is close to max. values specified in table.

Δp_{max} values are set for the most unfavourable pressure ratios on the valve PN 40, but in concrete cases the real Δp_{max} value can be higher than values specified in the table above.

Dimensions and weight for the type RV / UV 2x0 (Ex)

DN	PN 16					PN 40					PN 16, PN 40																			
	D ₁ mm	D ₂ mm	D ₃ mm	d mm	n	D ₁ mm	D ₂ mm	D ₃ mm	d mm	n	D mm	f mm	D ₄ mm	D ₅ mm	L mm	V ₁ mm	V ₂ mm	#V ₂ mm	V ₃ mm	#V ₃ mm	a mm	m ₁ kg	m ₂ kg	#m _v kg						
15	95	65	45	14	4	95	65	45	14	4	15	2	65	M10x1	130	51	90	257	220	387	16	4.5	5.5	3.5						
20	105	75	58			105	75	58			20				150	54	90	257	220	387	18	5.5	6.5	3.5						
25	115	85	68			115	85	68			25				160	58	100	267	230	397	18	6.5	8	3.5						
32	140	100	78			140	100	78			32				180	70	100	267	230	397	20	8	9.5	3.5						
40	150	110	88	18	4	150	110	88	18	4	40				2	65	M10x1	200	75	100	267	230	397	20	9	11	3.5			
50	165	125	102			165	125	102			50							230	85	132	339	262	469	20	14	21	4			
65	185	145	122			185	145	122			65							290	93	132	339	262	469	22	18	27	4			
80	200	160	138			200	160	138			80							310	105	164	482	294	612	24	26	40	4.5			
100	220	180	158	22	8	235	190	162	22	8	100							2	65	M16x1,5	350	118	164	482	294	612	24	38	49	4.5
125	250	210	188			270	220	188			125										400	135	183	501	313	631	26	58	82	5
150	285	240	212			22	8	26			150										480	150	200	518	330	648	28	78	100	5
												300	250	218																

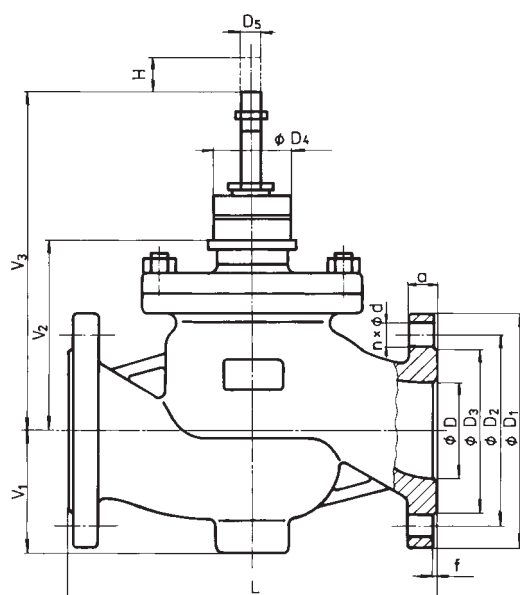

¹⁾ with regard of the standard previously in force, there is an option to have the number of connection bolts as stipulated in ČSN-EN 1092-1

^{#)} - for valve with bellows packing

m_v - weight to be added to weight of valve equipped with bellows packing

m₁ - for valves RV / UV 210 (Ex)

m₂ - for valves RV / UV 220 and RV / UV 230 (Ex)

RV 2x2 P (Ex)

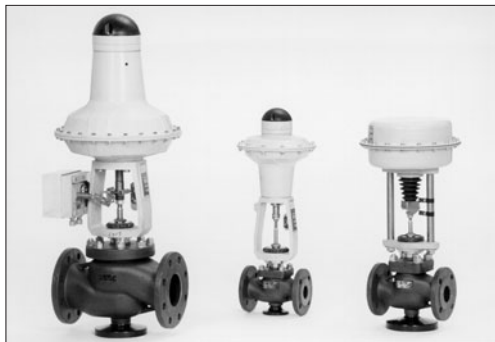

**Control valves
DN 25 - 150, PN 16 and 40
with SPA Praha pneumatic actuators**

Description

Control valves RV 212 (Ex), RV 222 (Ex) and RV 232 (Ex) [further only RV 2x2 (Ex)] are single-seated valves with pressure-balanced plug designed for regulation and shut-off of process medium flow. In regard of used actuators, the valves are suitable for regulation at high differential pressures with low-linear-force-actuators. Flow characteristics, Kvs values and leakage rates correspond to international standards. Valves RV 2x2 (Ex) are especially designed for pneumatic actuators of SPA Praha.

Application

The valves series RV 2x2 are designed for applications in heating, ventilation, power generation and chemical processing industries. The valves RV / UV 2x2 Ex meet the requirements II II 1/2G IIB acc. to ČSN-EN 13 463-1 (9/2002) and ČSN EN 1127-1 (9/1998), and in connection with suitable actuators, they are also designed for applications in gas and chemical industries. Valve body can be optionally made of spheroidal cast iron, cast steel and stainless steel.

The materials selected correspond to recommendations stipulated by ČSN-EN 1503-1 (1/2002) (steels) and ČSN-EN 1503-3 (1/2002) (cast). The maximal permissible operating pressures in behaviour with types of material and temperature are specified in the table on page 25 of this catalogue.

Process media

Valves series RV 2x2 are designed for regulation of flow and pressure of liquids, gases and vapours without abrasive particles e.g. water, steam, air and other media compatible with material of the valve inner parts. The valves series RV 2x2 Ex are designed also for control and shut-off of the flow and pressure of technical and fuel gases and inflammable liquids. The usage of the valve made of spheroidal cast iron (RV 212) for steam is limited by the following parameters. The steam must be superheated (its dryness at valve outlet $x_1 \geq 0,98$) and inlet pressure $p_1 \leq 0,4$ MPa when differential pressure is of above-critical value, and $p_1 \leq 1,6$ MPa when differential pressure is of under-critical value. In case these two conditions are not kept, it is necessary to use the valve made of cast steel (RV 222). To ensure a reliable regulation, the producers recommends to pipe a strainer in front of the valve into pipeline or ensure in any other way that process medium does not contain abrasive particles or impurities.

Installation

The valve is to be piped the way so that the direction of medium flow will coincide with the arrows on the body.

The valve can be installed in any position except position when the actuator is under the valve body. When medium temperature exceeds 150°C, it is necessary to protect the actuator against glowing heat from the pipeline e.g. by the means of proper insulating of the pipeline and valve or by tilting the valve away from the heat radiation.

Technical data

Series	RV 212 (Ex)	RV 222 (Ex)	RV 232 (Ex)
Type of valve	Two-way, single-seated, control valve with pressure-balanced plug		
Nominal size range	DN 25 to 150		
Nominal pressure	PN 16, PN 40		
Body material	Spheroidal cast iron EN-JS 1025 (EN-GJS-400-10-LT)	Cast steel 1.0619 (GP240GH) 1.7357 (G17CrMo5-5)	Stainless steel 1.4581 (GX5CrNiMoNb19-11-2)
Seat material : DN 15 - 50	1.4028 / 17 023.6	1.4028 / 17 023.6	1.4571 / 17 347.4
DIN W.Nr./+ČSN DN 65 - 150	1.4027 / 42 2906.5	1.4027 / 42 2906.5	1.4581 / 42 2941.4
Plug material : DN 15 - 65	1.4021 / 17 027.6	1.4021 / 17 027.6	1.4571 / 17 347.4
DIN W.Nr./+ČSN DN 80 - 150	1.4027 / 42 2906.5	1.4027 / 42 2906.5	1.4581 / 42 2941.4
Operating temperature range	-20 to 260°C	-20 to 260°C	-20 to 260°C
Face to face dimensions	Section 1 acc. to ČSN-EN 558-1 (3/1997)		
Connection flanges	Acc. to ČSN-EN 1092-1 (4/2002)		
Flange faces	Type B1 (raised-faced) or Type F (female) acc. to ČSN-EN 1092-1 (4/2002)		
Type of plug	V-ported, perforated		
Flow characteristic	Linear, equal-percentage, LDMspline®, parabolic		
Kvs value	4 to 360 m ³ /hour		
Leakage rate	Class III. acc. to ČSN-EN 1349 (5/2001) (<0.1% Kvs) for c. valves with metal-metal seat sealing Class IV. acc. to ČSN-EN 1349 (5/2001) (<0.01% Kvs) for c. valves with metal-PTFE seat sealing		
Leakage rate for Ex version	Leakage rate 6 acc. to ČSN 13 3060 - section 2		
Rangeability r	50 : 1		
Packing	O - ring EPDM $t_{max}=140^{\circ}C$, DRSpack® (PTFE) $t_{max}=260^{\circ}C$, Exp. graphite, bellows $t_{max}=500^{\circ}C$		

Remark: For low operating temperatures (-200 to +250°C), it is possible to supply the valve RV 232 with body material made of 1.4308 (cast stainless steel).

Kvs values and differential pressures

Δp_{max} value is the valve max. differential pressure when open-close function is always guaranteed. In regard of service life of seat and plug, it is recommended so that permanent

differential pressure would not exceed 1.6 MPa. Otherwise it is suitable to use perforated plug or sealing surfaces of seat and plug with a hard metal overlay.

For further information on actuating, see actuators' catalogue sheets

		Pneumatic actuator			526 61		5222	
		Actuator function			direct	indirect	direct	indirect
		Spring range			40 - 200 kPa		100 - 200 kPa	
		Spring setting			75 - 235 kPa		100 - 200 kPa	
		Feeding pressure			320 kPa		320 kPa	
		Specification No. of actuator			52661.x21x	52661.x22x	5222x051...	5222x052...
		Marking in valve spec.No.			PJA, PJB		PJE, PJF	
		Linear force			1,88 kN		4 kN	
		Kvs [m ³ /hour]			Δp_{max}		Δp_{max}	
DN	H	1	2	3	kov	PTFE	kov	PTFE
25	16	10	6.3 ¹⁾	4.0 ¹⁾	4.00	4.00	4.00	4.00
32		16.0	10.0	6.3 ¹⁾	4.00	4.00	4.00	4.00
40		25.0	16.0	10.0	4.00	4.00	4.00	4.00
50	25	40.0	25.0	16.0	4.00	4.00	4.00	4.00
65		63.0	40.0	25.0	4.00	4.00	4.00	4.00
80	40	100.0	63.0	40.0	---	---	4.00	4.00
100		160.0	100.0	63.0	---	---	4.00	4.00
125		250.0	160.0	100.0	---	---	4.00	4.00
150		360.0	250.0	160.0	---	---	4.00	4.00

1) linear characteristic only

Max. differential pressures specified in table apply to PTFE and O-ring packing. Δp_{max} for bellows must be consulted with the producer.

Perforated plug available only with Kvs values in shadowed frames with the following restrictions:

- Perforated plug with Kvs value acc. to column No. 2 available with linear or parabolic characteristic only.

Max. differential pressure Δp for valves PN 16 must be 1.6 MPa.

Dimensions and weights for the type RV 2x2 (Ex)

DN	PN 16					PN 40					PN 16, PN 40													
	D ₁	D ₂	D ₃	d	n	D ₁	D ₂	D ₃	d	n	D	f	D ₄	D ₅	L	V ₁	V ₂	[#] V ₂	V ₃	[#] V ₃	a	m ₁	m ₂	[#] m _v
	mm	mm	mm	mm		mm	mm	mm	mm		mm	mm	mm	mm	mm	mm	mm	mm	mm	mm	mm	kg	kg	kg
25	115	85	68	14	4	115	85	68	14	4	25	2	65	M10x1	160	58	100	267	230	397	18	7	8.5	3.5
32	140	100	78	140		100	78	32	180		70				100	267	230	397	20	8.5	10	3.5		
40	150	110	88	150		110	88	40	200		75				100	267	230	397	20	8.5	10	3.5		
50	165	125	102	165		125	102	50	230		85				132	339	262	469	20	14.5	21	4		
65	185	145	122	18	4 ¹⁾	185	145	122	18	8	65	2	65	M16x1,5	290	93	132	339	262	469	22	18.5	27	4
80	200	160	138	200	160	138	80	310	105		164				482	294	612	24	27.5	42	4.5			
100	220	180	158	220	180	158	100	350	118		164				482	294	612	24	39	50	4.5			
125	250	210	188	250	210	188	125	400	135		183				501	313	631	26	60	84	5			
150	285	240	212	22	8	300	250	218	26	150	150	480	150	200	518	330	648	28	81	103	5			

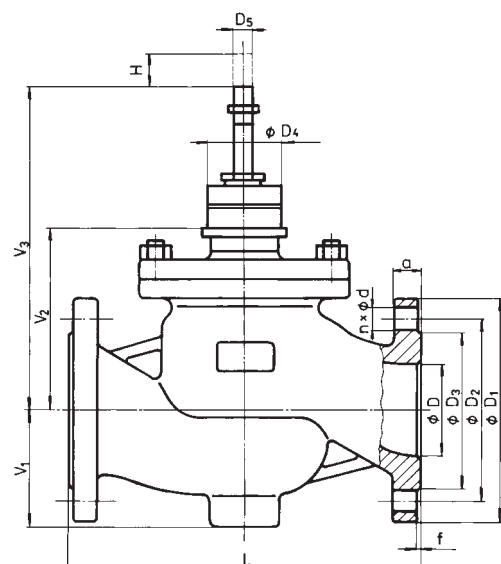

¹⁾ with regard of the standard previously in force, there is an option to have the number of connection bolts as stipulated in ČSN-EN 1092-1

^{#)} - for valve with bellows packing

m_v - weight to be added to weight of valve equipped with bellows packing

m_1 - for valves RV 212 (Ex)

m_2 - for valves RV 222 (Ex) and RV 232 (Ex)



Control valves DN 15 - 150, PN 16 and 40 with SPA Praha pneumatic actuators

Description

Control valves RV 214, RV 224 and RV 234 (further only RV 2x4) are three-way valves with mixing or flow-diverting function. In regard of used actuators, the valves are suitable for regulation at low and medium high differential pressures. Flow characteristics, Kvs values and leakage rates correspond to international standards.

Valves RV 2x4 are especially designed for pneumatic actuators of SPA Praha.

Application

These valves have a wide range of application in heating, ventilation, power generation and chemical processing industries. Valve body can be optionally made of spheroidal cast iron, cast steel and austenitic stainless steel according to operating conditions.

The materials selected correspond to recommendations stipulated by ČSN-EN 1503-1 (1/2002) (steels) and ČSN-EN 1503-3 (1/2002) (cast). The maximal permissible operating pressures in behaviour with types of material and temperature are specified in the table on page 28 of this catalogue.

Process media

Valves series RV 2x4 are designed for regulation of flow and pressure of liquids, gases and vapours without abrasive particles e.g. water, steam, air and other media compatible with material of the valve inner parts. The usage of the valve made of spheroidal cast iron (RV 214) for steam is limited by the following parameters. The steam must be superheated (its dryness at valve outlet $x_2 \geq 0,98$) and inlet pressure $p_i \leq 0,4$ MPa when differential pressure is of above-critical value, and $p_i \leq 1,6$ MPa when differential pressure is of under-critical value. In case these two conditions are not kept, it is necessary to use the valve made of cast steel (RV 224). To ensure a reliable regulation, the producer recommends to pipe a strainer in front of the valve into pipeline or ensure in any other way that process medium does not contain abrasive particles or impurities.

Installation

When the valve is used as mixing, it must be piped the way so that direction of process medium flow will coincide with the arrows on the body (inlet ports A, B and outlet port AB). When the valves is used as diverting, process medium flows through common valve port AB and split streams leave through valve ports A and B.). The valve can be installed in any position except position when the actuator is under the valve body. When medium temperature exceeds 150°C, it is necessary to protect the actuator against glowing heat from the pipeline; e.g. by the means of proper insulating of the pipeline and valve or by tilting the valve away from the heat radiation.

Technical data

Series	RV 214	RV 224	RV 234
Type of valve	Three-way, single-seated, reverse, control valve		
Nominal size range	DN 25 to 150		
Nominal pressure	PN 16, PN 40		
Body material	Spheroidal cast iron EN-JS 1025 (EN-GJS-400-10-LT)	Cast steel 1.0619 (GP240GH) 1.7357 (G17CrMo5-5)	Stainless steel 1.4581 (GX5CrNiMoNb19-11-2)
Seat material : DN 15 - 50	1.4028 / 17 023.6	1.4028 / 17 023.6	1.4571 / 17 347.4
DIN W.Nr./+ČSN DN 65 - 150	1.4027 / 42 2906.5	1.4027 / 42 2906.5	1.4581 / 42 2941.4
Plug material : DN 15 - 65	1.4021 / 17 027.6	1.4021 / 17 027.6	1.4571 / 17 347.4
DIN W.Nr./+ČSN DN 80 - 150	1.4027 / 42 2906.5	1.4027 / 42 2906.5	1.4581 / 42 2941.4
Operating temperature range	-20 to 300°C	-20 to 500°C	-20 to 400°C
Face to face dimensions	Section 1 acc. to ČSN-EN 558-1 (3/1997)		
Connection flanges	Acc. to ČSN-EN 1092-1 (4/2002)		
Flange faces	Type B1 (raised-faced) or Type F (female) acc. to ČSN-EN 1092-1 (4/2002)		
Type of plug	V-ported, contoured		
Flow characteristic	Linear, equal-percentage in direct way		
Kvs value	1.6 to 360 m ³ /hour		
Leakage rate	Class III. acc. to ČSN-EN 1349 (5/2001) (<0.1% Kvs) for c. valves with metal-metal seat sealing Class IV. acc. to ČSN-EN 1349 (5/2001) (<0.01% Kvs) for c. valves with metal-PTFE seat sealing		
Regentability r	50 : 1		
Packing	O - ring EPDM $t_{max}=140^{\circ}C$, DRSpack® (PTFE) $t_{max}=260^{\circ}C$, Exp. graphite, bellows $t_{max}=500^{\circ}C$		

Remark: For low operating temperatures (-200 to +250°C), it is possible to supply the valve RV 234 with body material made of 1.4308 (cast stainless steel).

Kvs values and differential pressures

Δp_{max} value is the valve max. differential pressure when open-close function is always guaranteed. In regard of service life of seat and plug, it is recommended so that permanent

differential pressure would not exceed 1.6 MPa. Otherwise it is suitable to use perforated plug or sealing surfaces of seat and plug with a hard metal overlay.

For further information on actuating, see actuators' catalogue sheets

Pneumatic actuator	526 61		5222	
Fail-safe action	direct	indirect	direct	indirect
Spring range	40-200 kPa		100 - 200 kPa	
Spring setting	75 - 235 kPa		100 - 200 kPa	
Feeding pressure	320 kPa		320 kPa	
Spec. No. of actuator	52661.x21x	52661.x22x	5222x051...	5222x052...
Mark in valve spec. No.	PJA, PJB		PJE, PJF	
Linear force	1,88 kN		4 kN	

DN	H	Kvs [m ³ /hour]			Δp_{max}		Δp_{max}	
		1	2	3	metal	PTFE	metal	PTFE
15	16	---	2.5 ¹⁾	1.6 ¹⁾	4.00	---	4.00	---
15		4.0 ¹⁾	---	---	4.00	---	4.00	---
20		---	---	2.5 ¹⁾	4.00	---	4.00	---
20		---	4.0 ¹⁾	---	4.00	---	4.00	---
20		6.3 ¹⁾	---	---	3.41	---	4.00	---
25		10	6.3 ²⁾	4.0 ²⁾	2.02	2.43	4.00	4.00
32		16.0	10.0	6.3 ²⁾	1.15	1.47	3.49	3.81
40		25.0	16.0	10.0	0.68	0.94	2.19	2.44
50	25	40.0	25.0	16.0	0.36	0.54	1.27	1.46
65		63.0	40.0	25.0	0.18	0.34	0.74	0.89
80	40	100.0	63.0	40.0	---	---	0.37	0.50
100		160.0	100.0	63.0	---	---	0.22	0.32
125		250.0	160.0	100.0	---	---	0.12	0.21
150		360.0	250.0	160.0	---	---	0.07	0.14

- 1) parabolic plug in straight way, V-ported plug in angle way
- 2) V-ported plug in angle way, in straight way for linear characteristic V-ported plug and for equal-percentage characteristic parabolic plug.

Bellows packing can be used with V-ported plug only.

Max. differential pressure Δp for valves PN 16 must be 1.6 MPa.

metal - version with metal - metal seat sealing
PTFE - version with metal - PTFE seat sealing (is not applicable to contoured plugs)

Max. differential pressures specified in table apply to PTFE and O-ring packing. Δp_{max} for bellows must be consulted with the producer. It applies to graphite packing as well especially when required Δp value is close to max. values specified in table.

Dimensions and weights for the type RV 2x4

DN	PN 16					PN 40					PN 16, PN 40															
	D ₁	D ₂	D ₃	d	n	D ₁	D ₂	D ₃	d	n	D	f	D ₄	D ₅	L	V ₁	V ₂	#V ₂	V ₃	#V ₃	a	m ₁	m ₂	#m ₁		
	mm	mm	mm	mm		mm	mm	mm	mm		mm	mm	mm	mm	mm	mm	mm	mm	mm	mm	mm	kg	kg	kg		
15	95	65	45			95	65	45			15				130	110	67	---	197	---	16	5.5	6	---		
20	105	75	58	14		105	75	58	14		20				150	115	67	---	197	---	18	6.5	7	---		
25	115	85	68		4	115	85	68		4	25			M10x1	160	130	72	239	202	369	18	8.3	9.5	3.5		
32	140	100	78			140	100	78			32		32				180	135	72	239	202	369	20	10.5	12	3.5
40	150	110	88			150	110	88			40		40				200	140	72	239	202	369	20	12	13.5	3.5
50	165	125	102			165	125	102	18			50	2		65		230	175	92	299	222	429	20	17	24	4
65	185	145	122	18	4 ¹⁾	185	145	122			65			M16x1,5	290	180	92	299	222	429	22	22	31	4		
80	200	160	138		200	160	138			80					310	220	123	441	253	571	24	31	43	4.5		
100	220	180	158		235	190	162	22	8	100					350	230	123	441	253	571	24	44	55	4.5		
125	250	210	188		270	220	188	26		125					400	260	151	469	281	599	26	65	90	5		
150	285	240	212	22		300	250	218			150			480	290	151	469	281	599	28	94	120	5			

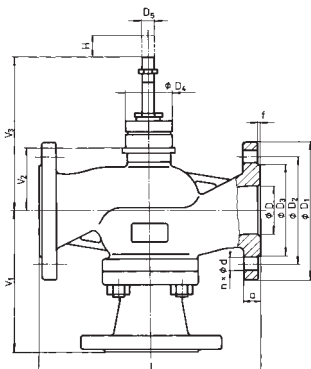

¹⁾ with regard of the standard previously in force, there is an option to have the number of connection bolts as stipulated in ČSN-EN 1092-1

#) - for valve with bellows packing

m_v- weight to be added to weight of valve equipped with bellows packing

m₁- for valves RV / UV 214

m₂- for valves RV / UV 224 and RV 234

Valve complete specification No. for ordering RV / UV 2x0 (Ex), RV 2x2 (Ex), RV 2x4

		XX	X X X	X X X	X X X X	X X	- XX	/ XXX	- XXX	XX
1. Valve	Control valve	RV								
	Shut-off valve	UV								
2. Series	Valves made of spheroidal cast iron EN-JS 1025		2 1							
	Valves made of cast steel 1.0619, 1.7357		2 2							
	Valves made of stainless steel 1.4581		2 3							
	Direct valve		0							
	Pressure-balanced, direct valve		2							
	Mixing (diverting) valve		4							
3. Actuating	Pneumatic actuator			P						
	Pneu. actuator 526 61.xxx1			P J A						
	Pneu. actuator 526 61.xxx2 (w. corector)			P J B						
	Pneu. actuator 5222xxxx1xx			P J E						
	Pneu. actuator 5222xxxx2xx (w. corector)			P J F						
4. Connection	Raised flange				1					
	Female flange				2					
5. Body material	Cast steel 1.0619 (-20 to 400°C)				1					
	Sphr. cast iron EN-JS 1025 (-20 to 300°C)				4					
	CrMo steel 1.7357 (-20 to 500°C)				7					
	Stainless steel 1.4551 (-20 to 400°C)				8					
	Other material on request				9					
<i>(Operating temperature ranges are specified in parentheses)</i>										
6. Seat sealing	Metal - metal				1					
	Soft sealing (metal - PTFE) ¹⁾				2					
	Hard metal overlay on sealing surfaces				3					
7. Packing	O - ring EPDM ³⁾				1					
	DRSpack® (PTFE)				3					
	Graphite ^{2) 3)}				5					
	Bellows				7					
	Bellows with safety PTFE packing				8					
	Bellows with safety Graphite packing ²⁾³⁾				9					
8. Flow characteristic	Linear					L				
	Equal-percentage in straight way					R				
	LDMspline® ⁵⁾					S				
	On-off ⁴⁾					U				
	Parabolic ⁵⁾					P				
	Linear - perforated plug ⁵⁾					D				
	Equa -percentage - perforated plug ⁵⁾					Q				
	Parabolic - perforated plug ⁵⁾					Z				
9. Kvs	Column No. acc. to Kvs values table					X				
10. Nominal pressure PN	PN 16						16			
	PN 40						40			
11. Max. operating temp. °C	O - ring EPDM							140		
	DRSpack® (PTFE), bellows							220		
	DRSpack® (PTFE), bellows							260		
	Exp. graphite; Bellows ²⁾							300		
	Exp. graphite; Bellows ²⁾							400		
	Exp. graphite; Bellows ²⁾							500		
12. Nominal size DN	DN								XXX	
13. Execution	Normal									
	Non - explosive									Ex

Ordering example: Two-way control valve DN 65, PN 40, with pneumatic actuator 526 63.2111, body material: spheroidal cast iron, flange with raised face, metal-PTFE seat sealing, PTFE packing, linear characteristic, Kvs = 63 m³/hour is specified as follows: **RV 210 PJC 1423 L1 40/220-65.**

Valves RV / UV 2x0 (Ex)

Section of valve with V-ported plug

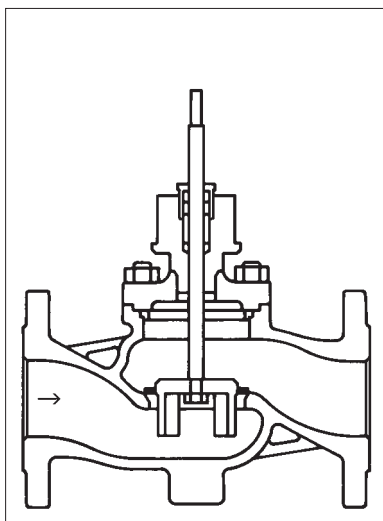

Section of valve with perforated plug

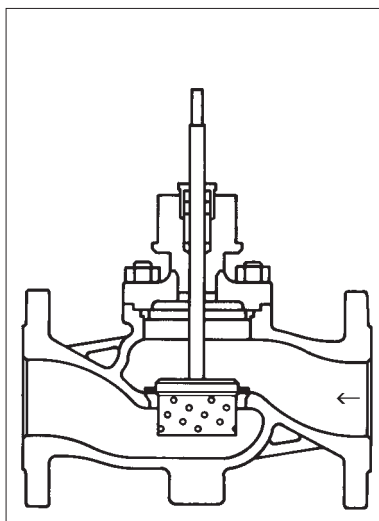

Section of valve with micro-throttling system

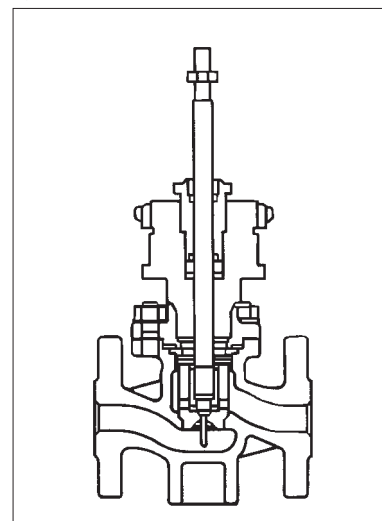

Valves RV 2x2 (Ex)

Section of pressure-balanced valve with V-ported plug

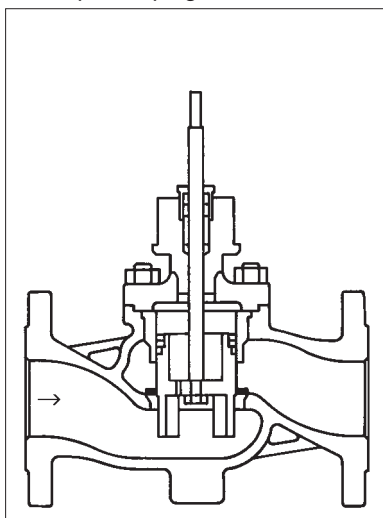

Section of pressure-balanced valve with perforated plug

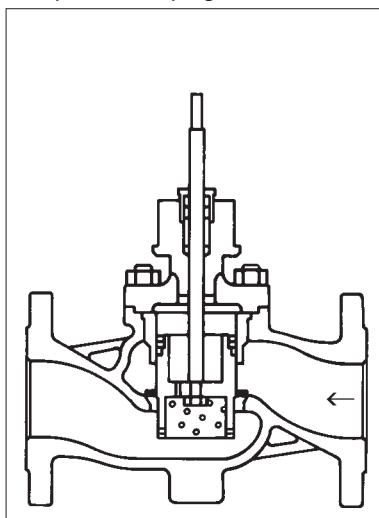

Valves RV 2x4

Section of three-way valve with V-ported plug

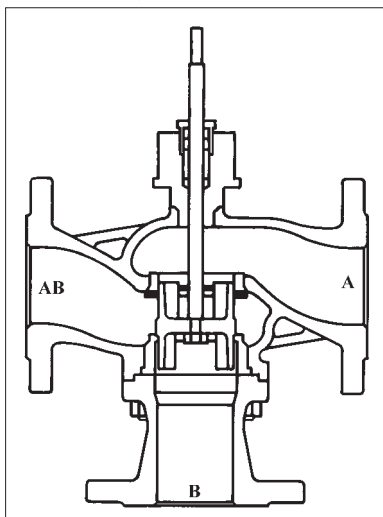

PJA, PJB



Pneumatic actuators 526 61 SPA Praha

Technical data

Type	526 61	
Marking in valve specification No.	PJA (without corector)	
	PJB (with corector)	
Feeding pressure	max. 320 kPa	
Fail-safe action	direct	indirect
Control	ON - OFF	
	Pneumatic signal 20 - 100 kPa (with corector)	
	Current signal 4 - 20 mA (with E/P positioner)	
Nominal force	Acc. to execution of actuator	
Travel	16, 25 mm	
Enclosure	IP 53	
Process medium max. temperature	Acc. to used valve	
Ambient temperature range	-35 to 70°C	
Ambient humidity range	5 - 100 %	
Weight	14,5 kg (with corector)	
	12 kg (without corector)	

Accessories

Pneumatic corector	serves for adjusting of required stroke value with the aid of pneumatic signal 20 to 100kPa
Electropneumatic converter (type 121 14)	equipped with electric input 4 (0) to 20 mA and pneumatic output 20 to 100 kPa to control corector
Air set (type 357 18)	reduces control air pressure to required value
Elektropneumatic positioner (type 6503)	equipment with electric input 4 (0) to 20 mA and direct output of control air into actuator (corector is not required)
Signalisation switches	adjustable end position switches
Position transmitter	resistance output signal (0 to 1000 Ω)
	2 - wire output 4 - 20 mA

Operating conditions

Pneumatic actuators can be installed in open atmosphere. They can operate in explosive environment acc. to class SNV1 to SNV3. If there is any additional electric equipment used in actuator, then its application in environment SNV is limited by this additional equipment. Further they can operate at vibration of max. 55 Hz; 15 mm.

Direct and indirect functions

Direct function ensures that actuator stem (draw bar) retracts upon air supply failure (valve opens). Indirect function ensures that actuator stem (draw bar) extends upon air supply failure (valve closes).

Notes

For version with corector, operating spring range can be altered by changing spring preloading for purpose to increase linear force in case of air supply failure. Changes are as follows:

- from 20 - 100 kPa to 60 - 140 kPa
- from 40 - 200 kPa to 80 - 240 kPa

Feeding pressure must be increased proportionately to it. This pressure must not be higher than 320 kPa, otherwise an air set is required to be used.

Specification of actuators 526 61

Pneumatic diaphragm servomotor, single acting, with clutch	526 6	X	X	X	X	X
Effective diaphragm area	250 cm ²	1				
Travel	16 mm (type 562 61)		1			
	25 mm (type 526 61 and 526 63)		2			
Operating spring range	20 - 100 kPa			1		
	40 - 200 kPa			2		
Fail-safe action	Direct				1	
	Indirect				2	
Execution	Without corector					1
	With corector					2

Dimensions of actuators 526 61

Actuator with direct function

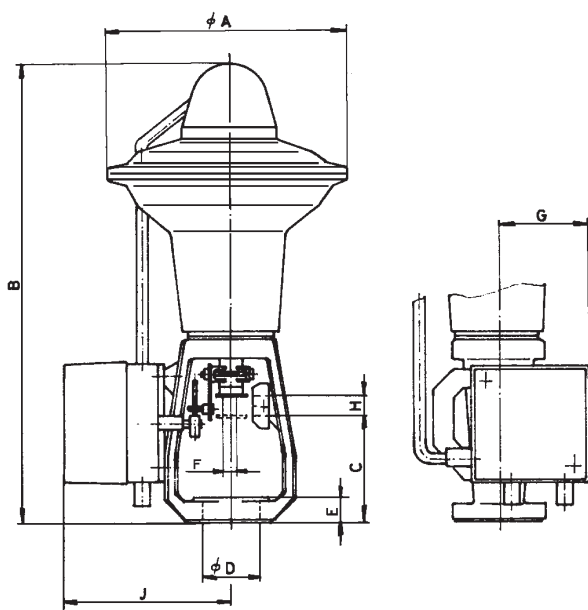

Actuator with indirect function

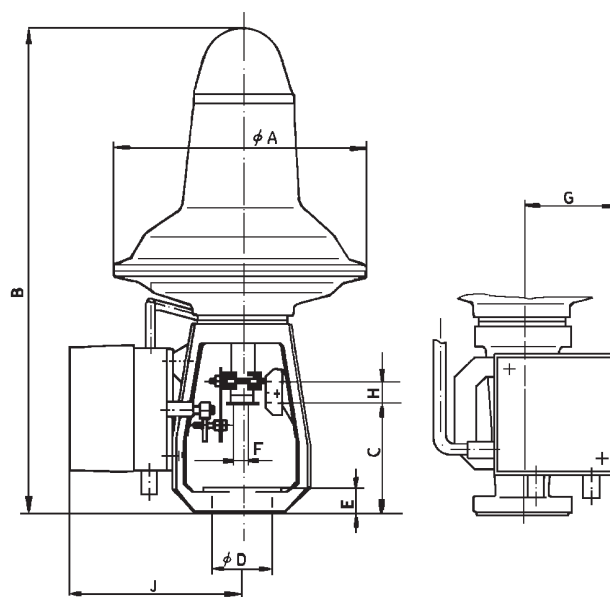

	A	B	C	D	E	F	G	H	J
526 61	250	487	110	65	25	M 10x1	113	16, 25	172

PJE, PJF



Pneumatic actuators 5222 SPA Praha

Technical data

Type	5222
Marking in valve specification No.	PJE (without corector) PJF (with corector)
Feeding pressure	max. 350 kPa
Fail-safe action	Direct and indirect
Control	ON - OFF Pneumatic signal 20 - 100 kPa (with positioner 6503) Current signal 4 - 20 mA (with positioner 6503)
Nominal force	acc. to used actuator
Travel	16, 25, 40 mm
Enclosure	IP 53
Process medium max. temperature	Acc. to used valve
Ambient temperature range	-25 to 70°C
Ambient humidity range	5 - 100 %
Weight	34,2 kg (with corector) 31 kg (without corector)

Accessories

Pneumatic positioner (corector) (type 650 01)	serves for adjusting of required stroke value with the aid of pneumatic signal 20 to 100kPa
Position converter (type 650 11)	additional equipment for actuators without positioner or for actuators equipped with pneumatic positioner - adjustable end position signalization switches - resistance feedback of 1kΩ - two-wire current feedback 4 - 20mA of actuator position
Air set (type A3420)	reduces input pressure to 1,6 MPa to a free adjustable stabilized pressure ranging from 50 to 600 kPa
Electropneumatic positioner (type SPS2)	positioner controlled by microprocesor. Input signal 4-20mA It can include end position switches and feedback 4-20 mA
Electropneumatic positioner (type 6503)	serves as a proportional positioner. Input control pressure 4 - 20 mA. It may have the same output signals as position converter (type 650 11)
Signalisation switches	adjustable end position switches
Position transmitter	resistance output signal (0 to 1000 Ω) 2 - wire output 4 - 20 mA
Solenoid valve	serves for direct control or to induce fail-safe action . If the chosen fail-safe action of actuator shall be preserved, it is necessary to choose a solenoid valve with NC fail-safe action
Manual operating	for fail to open (NO) or fail to close function (NC) of actuator

Operating conditions

Pneumatic actuators can be installed in open atmosphere. They can operate in explosive environment acc. to class SNV1 to SNV3. If there is any additional electric equipment used in actuator, then its application in environment SNV is limited by this additional equipment.

Direct and indirect functions

Direct function ensures that actuator stem (draw bar) retracts upon air supply failure (valve opens).
Indirect function ensures that actuator stem (draw bar) extends upon air supply failure (valve closes).

Specification of actuator 5222

Pneumatic diaphragm servomotor, single acting, with clutch		5222	X	X	X	X	X	X	X
Travel	16 mm	1							
	25 mm	2							
	40 mm	4							
Operating spring range	20 - 100 kPa (force 4 kN; 6,3 kN for NO fail-safe action)		0	1					
	100 - 200 kPa (force 4 kN, 2x4 kN for three-way valves)		0	5					
	160 - 300 kPa (force 6,3 kN for NC fail-safe action)		0	9					
	160 - 300 kPa TANDEM (force 12,5 kN for NC fail-safe action)		1	9					
Fail-safe action	Ditrect: NO					1			
	Indirect: NC					2			
Execution	Without corector						1		
	With corector						2		
Manual operating	Without manual operating							0	
	With manual operating							1	
Additional equipment	Without additional equipment								0
	With additional equipment to normal atmosphere								1
	With additional equipment to explosive surroundings of class SNV								3

Dimensions of actuator 5222

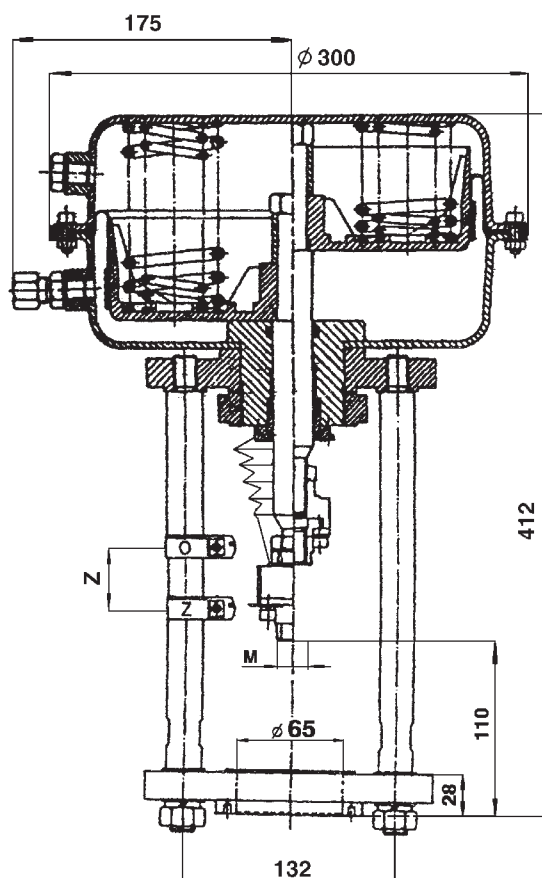

Maximal permissible operating pressures [MPa]

Material	PN	Temperature [°C]										
		120	150	200	250	300	350	400	450	500	525	550
Spheroidal cast iron EN-JS 1025 (EN-GJS-400-18LT)	16	1,50	1,40	1,40	1,30	1,10	---	---	---	---	---	---
	40	4,00	3,88	3,60	3,48	3,20	---	---	---	---	---	---
Cast Steel 1.0619 (GP240GH)	16	1,60	1,50	1,40	1,30	1,10	1,00	0,80	---	---	---	---
	40	4,00	4,00	3,90	3,60	3,20	2,70	1,90	---	---	---	---
Chrommolybden steel 1.7357 (G17CrMo5-5)	---	---	---	---	---	---	---	---	---	---	---	---
	40	4,00	4,00	4,00	4,00	4,00	4,00	3,90	3,10	1,80	---	---
Stainless steel 1.4581 (GX5CrNiMoNb19-11-2)	16	1,60	1,50	1,40	1,30	1,30	1,20	1,20	---	---	---	---
	40	4,00	3,80	3,50	3,40	3,30	3,10	3,00	---	---	---	---

Notes:



LDM, spol. s r.o.
Litomyšlská 1378
560 02 Česká Třebová
Czech Republic

tel.: +420 465 502 511
fax: +420 465 533 101
E-mail: sale@ldm.cz
<http://www.ldm.cz>

LDM, spol. s r.o.
Büro Prague
Tiskařská 10
108 28 Praha 10 - Malešice
Czech Republic

tel.: +420 234 054 190
fax: +420 234 054 189

LDM, spol. s r.o.
Büro Ústí nad Labem
Mezní 4
400 11 Ústí nad Labem
Czech Republic

tel.: +420 475 650 260
fax: +420 475 650 263

LDM servis, spol. s r.o.
Litomyšlská 1378
560 02 Česká Třebová
Czech Republic

tel.: +420 465 502 411-3
fax: +420 465 531 010
E-mail: servis@ldm.cz

LDM, Polska Sp. z o.o.
Modelarska 12
40 142 Katowice
Poland

tel.: +48 32 730 56 33
fax: +48 32 730 52 33
mobile: +48 601 354999
E-mail:
ldmpolska@ldm.cz

LDM Bratislava s.r.o.
Mierová 151
821 05 Bratislava
Slovakia

tel.: +421 2 43415027-8
fax: +421 2 43415029
E-mail: ldm@ldm.sk
<http://www.ldm.sk>

LDM - Bulgaria - OOD
z. k. Mladost 1
bl. 42, floor 12, app. 57
1784 Sofia
Bulgaria

tel.: +359 2 9746311
fax: +359 2 9746311
GSM: +359 88 925766
E-mail: ldm.bg@mbox.cit.bg

OAO "LDM"
Chernyakhovskogo str., build. 4
125319 Moskau
Russian Federation

tel.: +7 095 7973037
fax: +7 095 7973037
E-mail: inforus@ldmvalves.com

LDM Armaturen GmbH
Wupperweg 21
D-51789 Lindlar
Germany

tel.: +49 2266 440333
fax: +49 2266 440372
mobile: +49 177 2960469
E-mail: ldmarmaturen@ldmvalves.com
<http://www.ldmvalves.com>

Your partner